



EMDS Cable Conduit Programme

Energy | Media | Data | Signal

3. Installation guideline

These general installation instructions apply to buried conduit pipes made of polyethylene. They are complementary to existing specific standards and guidelines of DIN, DWA, DVGW, DIN CERTCO, DVS and KRV.

The limits of use and performance of the pipes in the different performance classes must be respected. Especially, for the jointing techniques, it is necessary also to adhere to the separate instructions issued by each of the different joint manufacturers.

3.1 Handling

Polyethylene plastic pipes are transported in the form of straight lengths, coiled bundles or reels. They shall be properly handled, loaded and unloaded.

Upon delivery or just before the installation, an optical inspection of the pipe shall be carried out. Also, the information printed on the pipe shall be checked and the jointing zones shall be cleaned. Damaged parts will be discarded. Cuts can be made with a fine-toothed saw or a plastic pipe cutter. Guided saws, e.g. mitre boxes, allow cuts perpendicular to the pipe axis. Burrs and irregularities along the parting planes shall be removed with a suitable tool, e.g. a blade or scraper knife. The pipe ends need to be treated according to the jointing technique.

Dirt or incrustations on the inner faces and damages in general shall be prevented. Pipes shall not be dragged along ground or floors. Scoring, scratches or surface abrasions up to 10 % of the minimum wall thickness in PE80 and PE100 pipes are

PE-HD pipes and pipelines shall be processed and laid by well-trained specialist staff only. This is especially true for welding.

The rules of accident prevention of the employers insurance liability company shall be observed during installation. The road traffic regulations are of special importance for any work within traffic zones; the guidelines for safety measures at roadworks site shall be adhered to.

tolerable. Pipes with more severe damage are not allowed to be installed (DVGW Worksheet W 400-2/September 2004). Also, lasting deformation of the pipes must be prevented. The storage area should be level and free of stones or sharp-edged objects.

Black PE-HD pipes are sufficiently protected from UV radiation due to their very nature (increased carbon black content in the material). They remain safe even after a longer time/several years of storage in the open air.

Coloured PE-HD pipes (e.g. red, white) must be subjected to a usability check if exposed to radiation of 7.0 GJ/m², which is equivalent to two years of non-protected storage with direct sunlight exposure in Germany. The manufacturer can validate and release the pipes for further use.

The pipes shall be protected from contact with substances that are detrimental to PE (→ Technical Information, p. 61 et seq.).

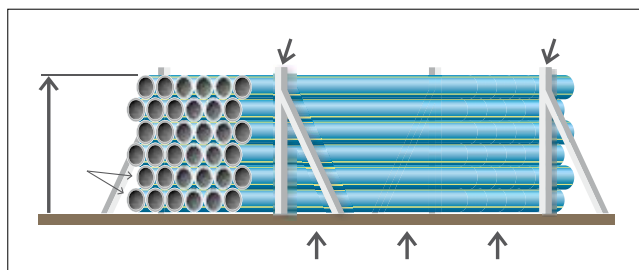

8.13 Correct storage of EMDS straight pipes without wooden framework

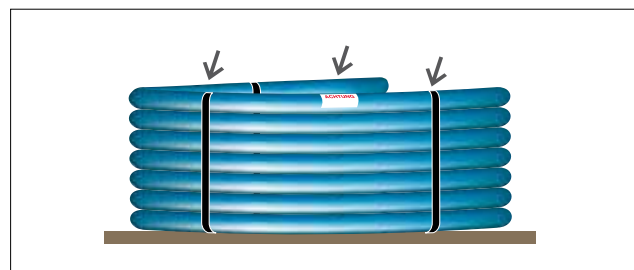

8.14 Correct storage of EMDS pipe coils

Product-specific instructions

PE pipes in straight lengths

During transport, handling and storage, straight pipes should be supported substantially along their entire length and secured from rolling apart. Furthermore, appropriate retainers will prevent non-palletised pipes from rolling to the sides, for which purpose the pipe stack shall be arranged in straight and staggered layers. The maximum allowable stack height is 1.0 m (SDR classes ≥ 26 minus 0.5 m).

! Thin-walled pipes of the classes SDR 21 to 33 shall be protected from direct sunlight (e.g. with white tarpaulin or fleece) to mitigate the risks of deflection and deformation.

PE-pipes in coils

Coiled pipe bundles shall be stored in horizontal position or in suitable racks. The holding straps or bands shall not be removed until immediately before installation. The information labelled on the coils shall be adhered to.

PE pipes wound on reels

Reels (drums) – especially the Gerodur large-reel system – shall be handled in compliance with the safety and handling instructions attached to them.

Improper handling of reels presents a risk to human health and equipment integrity. For **loading and unloading with a crane** it is therefore necessary to use appropriate spreader bars preventing any damage to the reel and pipe.

If **fork lift trucks** are used, they need to be equipped with specific attachments for reels.

Reels are not allowed to be stacked in storage. They shall be stored in vertical position and secured from rolling. Advantageously, storage areas should have a hard level surface.

Thermal expansion/contraction needs to be taken into account for cutting and laying the pipes. A rise in temperature will cause an increase in the length of the pipe. A drop in temperature causes a PE pipe to shorten by 0.2 mm per metre and K (→ Technical Information, p. 46).

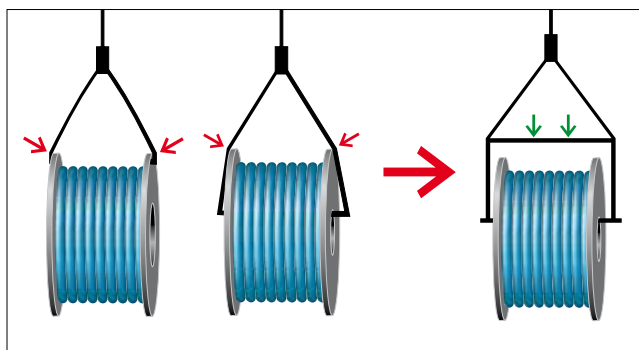

8.15 Loading and unloading of reels with a crane

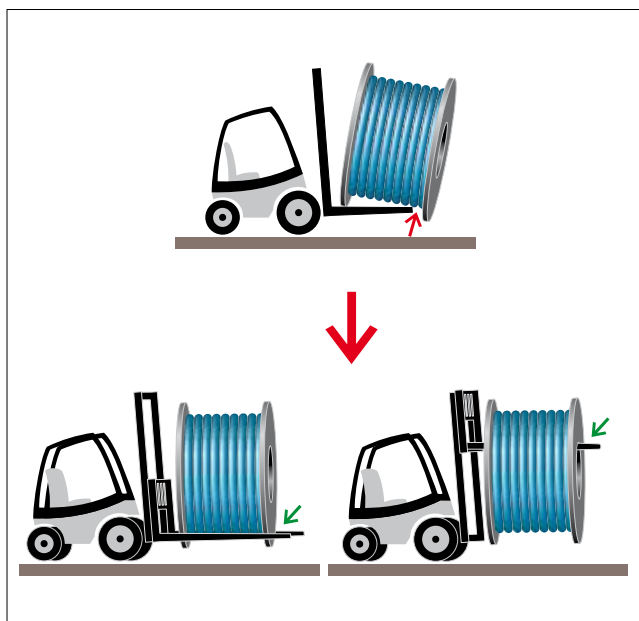

8.16 Handling of reels with a fork lift truck

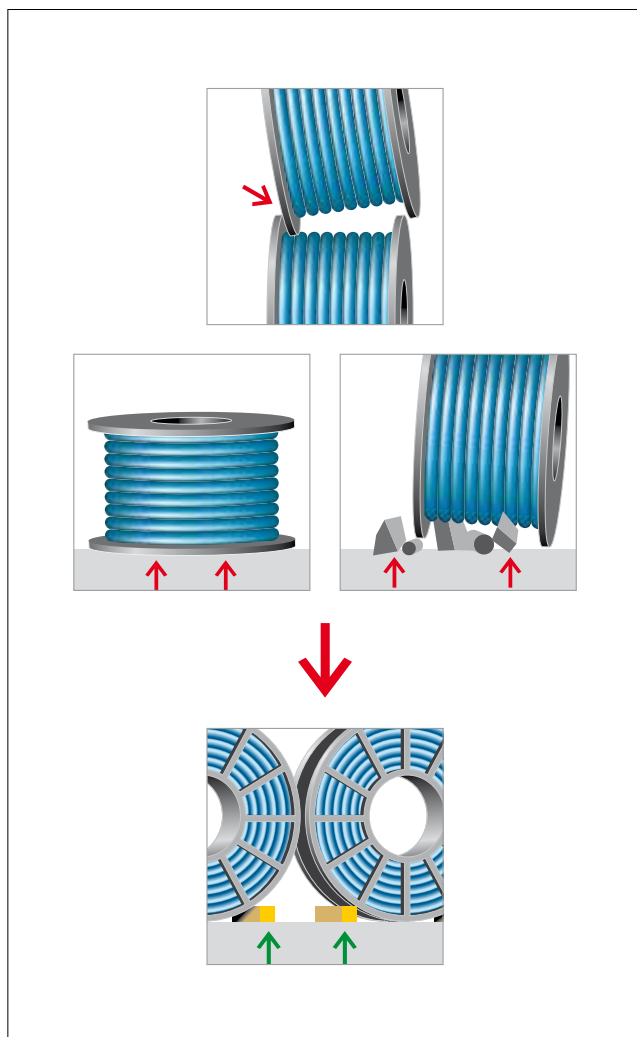

8.17 Correct storage of large-size reels

Unwinding

There are several ways how to uncoil pipes. In general, pipes having an outside diameter up to 63 mm are uncoiled in a vertical position. It is important to restrain the pipe ends when removing the holding straps or bands; otherwise, the pipe end might uncoil with extreme whipping force, especially in case of larger pipe diameters. Therefore, special care is required at this point (danger of accident!). It is wise to use an uncoiling aid. Coiled pipes lying on a wooden or steel carousel can be unwound in a straight line either by hand or via a slowly operating vehicle. Sharp bends (kinks) or spiral unwinding must be prevented.

During uncoiling, it is important to bear in mind that the degree of flexibility of PE pipes depends on ambient temperature. In case of near-frost temperatures pipes with a diameter of 75 mm or higher should, where possible, be warmed up while still in coil, e.g. with hot steam (max. 100°C).

For unwinding pipes on the construction site, a suitable reel handling vehicle or other appropriate equipment should be used (e.g. transporters by BAGELA Baumaschinen GmbH & Co. KG).

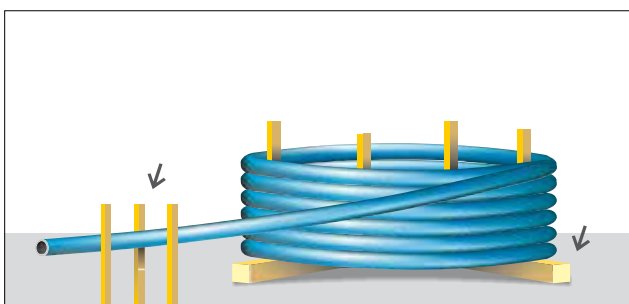

8.18 Decoiler

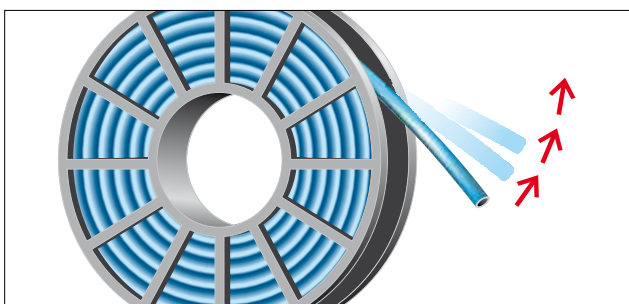

8.19 Caution: Whipping pipe end after removal of straps

3.2 Installation

Trenching with sand bedding

Construction of pipe trench

The pipe trench shall be constructed according to DIN 4124. The backfill soil shall be assessed according to ZTV A-StB and DIN 18196. Installation work in public spaces is governed by DIN 1998.

No traffic load	Traffic load up to SLW60 (heavy load vehicle)
≤ SDR 33	≤ SDR 17
0.8 to 4m	0.8 to 5m

8.20 Recommended installation depths

DN/OD [mm]	Minimum trench width $b (d_n + x)$ [m]			
	Sheeted trench		Non-sheeted (sloped) trench	
	Typical	Bracing	$\beta > 60^\circ$	$\beta \leq 60^\circ$
≤ 400	$d_n + 0.4$	$d_n + 0.7$	$d_n + 0.4$	$d_n + 0.4$
> 400	$d_n + 0.7$	$d_n + 0.7$	$d_n + 0.7$	$d_n + 0.4$

8.21 Trench width as a function of pipe size and slope angle according to DIN 4124

Depth of backfill cover $h+d_n$ [m]	Minimum trench width b [m]	
≤ 1.75	sloped 0.6	sheeted 0.7
> 1.75 to ≤ 4.0	0.8	
> 4.0	1.0	

8.22 Trench width as a function of pipe diameter and backfill cover according to DIN 4124

The minimum trench width b shall be the higher of the values depending on the nominal diameter (DN/OD) and the trench depth ($h+d_n$).

For the values for d_n+x , $0.5x$ is equivalent to the minimum working space between pipe and trench wall or trench sheeting according to DIN 4124. The trench bottom shall be constructed so as to evenly support the pipeline.

Bedding construction in the pipe zone

The pipe zone (up to 0.3m above pipe crown) shall be filled with compactable material such as sands and gravels with a grain size of $gG=0-22$ mm for round-grain material and $gG=0-11$ mm for crushed material (according to DVGW W 400-2). Embedding and compaction shall be done by hand or with a lightweight compactor.

Specific features of the trench zone

When the pipe is laid in rock or stony soil, the support layer thickness (lower bedding layer) must be increased to 0.15m, i.e. excavation must be 0.15m deeper. The compactable material to be used for the support layer is sands and gravels having a grain size of $gG=0-22$ mm for round-grain material and $gG=0-11$ mm for crushed material (according to DVGW W 400-2).

Backfill above pipe zone

The pipe trench backfill above the pipe zone shall be placed and compacted layer by layer according to the design requirements. Suitable backfill materials are the material already placed in the pipe zone or the materials specified by ZTV A-StB.

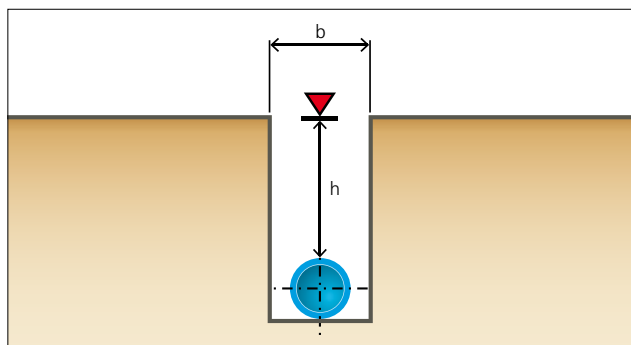

8.23 Pipe trench – open construction

- DN/OD...nominal size as referred to the outside diameter [mm]
- d_n nominal outside diameter [m]
- β slope angle of the non-sheeted trench [°]
- b minimum trench width [m]
- h height zone [m]

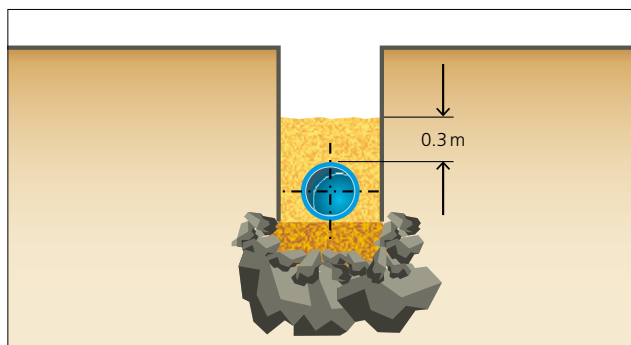

8.24 Bedding of pipe zone

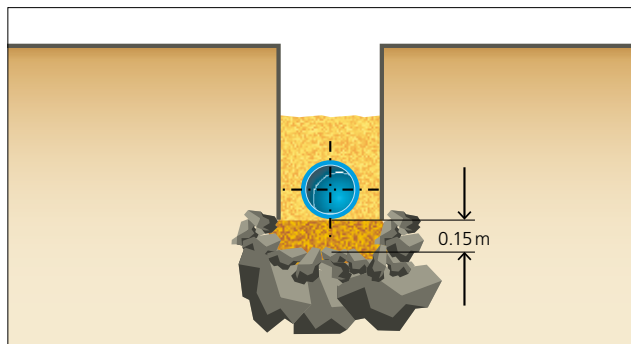

8.25 Lower bedding layer

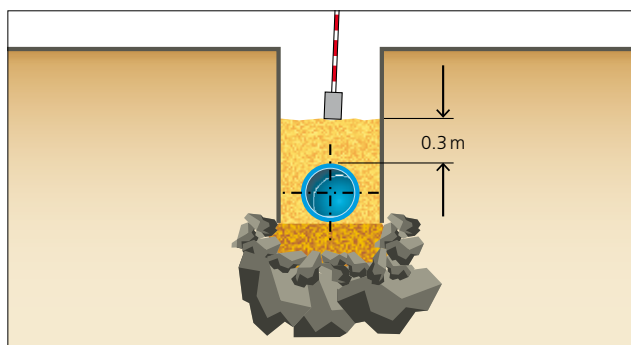

8.26 Construction of the pipe zone

Installation in trench without sand bedding

Bedding and backfill

EMDS conduit pipes made of suitable materials (e. g. PE100-RC) can be installed without sand bedding. This implies less work and cost for excavation and replacement of in-situ ground with bedding sand according to DIN EN 805 (transport and landfill). The pipe characteristics require no grain size restrictions for bedding and backfill materials. Installation work in the public space

(e. g. roadworks) must be in compliance with further requirements, standards and guidelines:

- DIN V ENV 1046
- DIN EN 805
- DIN 4124
- DIN EN ISO 14688
- DIN 18123
- ZTV A-StB
- DIN 18196
- ZTV E-StB

Low-dig and no-dig (trenchless) installation

Trenchless installation techniques cause higher stress and loads than the conventional open-trench construction of a pipeline.

Installers must comply with the relevant DVGW worksheets and method instructions for the different trenchless laying techniques to maintain constant quality standards:

- Relining (rehabilitation) according to DVGW GW 320
- Controllable horizontal directional drilling according to DVGW GW 321
- No-dig replacement using pushing or pulling procedures according to DVGW GW 322
- No-dig renewal by pipe bursting procedure according to DVGW GW 323
- No-dig construction types for gas and water connection lines according to DVGW GW 325 (non-finalised draft)

This includes the installation of new pipes by ploughing and milling (low-dig) procedures, because the furrows and narrow trenches thus created are no conventional pipe trenches as defined in DIN 4124.

- Milling and ploughing procedures according to DVGW GW 324

Trenchless pipeline installation operations require extensive planning and design. It is necessary to conduct a preliminary assessment of the existing piping structures or subsoil conditions to select then the installation procedure, the appropriate pipe, the pipe joint and the other parameters.

Trenchless pipe installation shall be recorded in a traceable documentation (including material certificates, test report with tensile forces, leak testing, CCTV inspection and other relevant processes).

Introduction of EMDS conduit pipes

The dimensions of the access pit vary according to the laying method. Generally, the bending radius of the pipe shall not fall below the respective allowable minimum – but short-term deviation is considered not to be critical. Kinking of the pipe must be prevented.

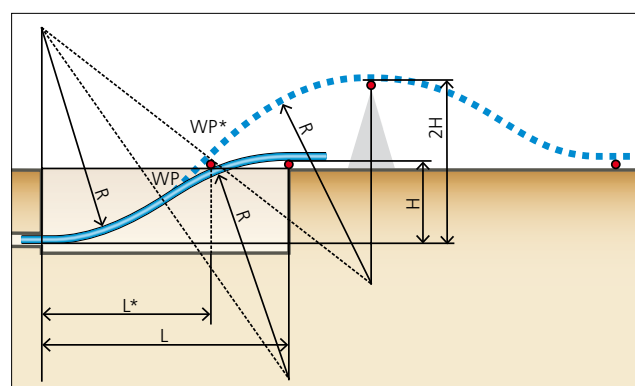

8.27 Determination of introduction lengths for EMDS conduit

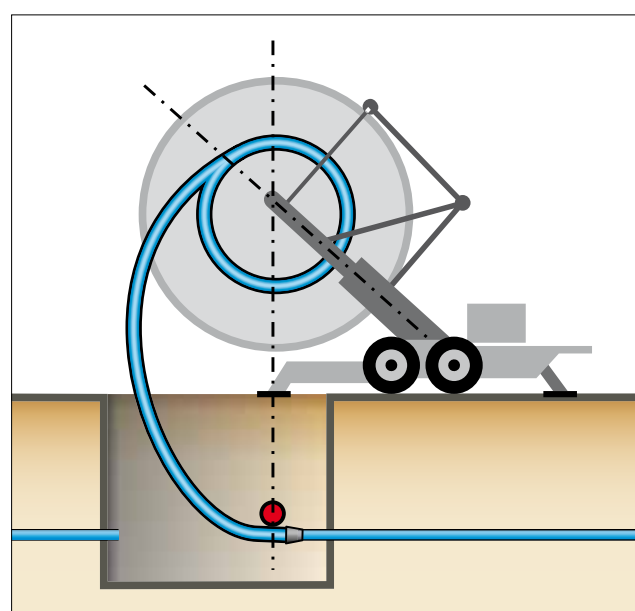

8.28 Introduction of EMDS conduit from coil or from large-size reel

- L.....length of access pit [m]
- L*.....reduced length of access pit [m]
- H.....pipe bottom depth [m]
- R.....allowable bending radius [m]
- WP.....turning point
- WP*.....possible turning point at smaller pipe dimensions (e. g. up to DN 300)

The length of the access pit [m] results from:

1.31

$$L = \sqrt{H \times (4 \times R - H)}$$

- L.....length of access pit [m]
- L*.....reduced length of access pit [m]
- H.....pipe bottom depth [m]
- R.....allowable bending radius [m]
- d_nnominal outside diameter [mm]

For smaller pipe diameters, the pit dimensions can be reduced by lifting the pipe according to the following formula:

1.32

$$L^* = \sqrt{H \times (2 \times R - H)}$$

Allowable bending radius: $R = 20 \times d_n$ at 20 °C
 → Technical information, p. 58

Milling and ploughing (DVGW GW 324)

These installation methods are typically used in rural areas and outside traffic zones. In both techniques it is important to adhere to the allowable bending radii and tensile forces of the piping system being laid (DVGW requirements).

Milling (narrow trenching) is an open-cut method for mechanically cutting a narrow trench into ground while placing the EMDS conduit pipe at the same time onto the bottom of the trench. The trench needs no sand bedding and can thus be mechanically backfilled, and compacted, with compactable

material removed during the cutting process. If required, it is also possible to construct a sand bedding with the help of the so-called laying box.

Ploughing is a minimum-dig method for displacing soft ground with a plough blade and placing the EMDS conduit via a laying box onto the bottom of the furrow thus produced. The method can achieve installation rates of up to four kilometres per day, depending on soil class, pipe diameter, installation depth and equipment used.

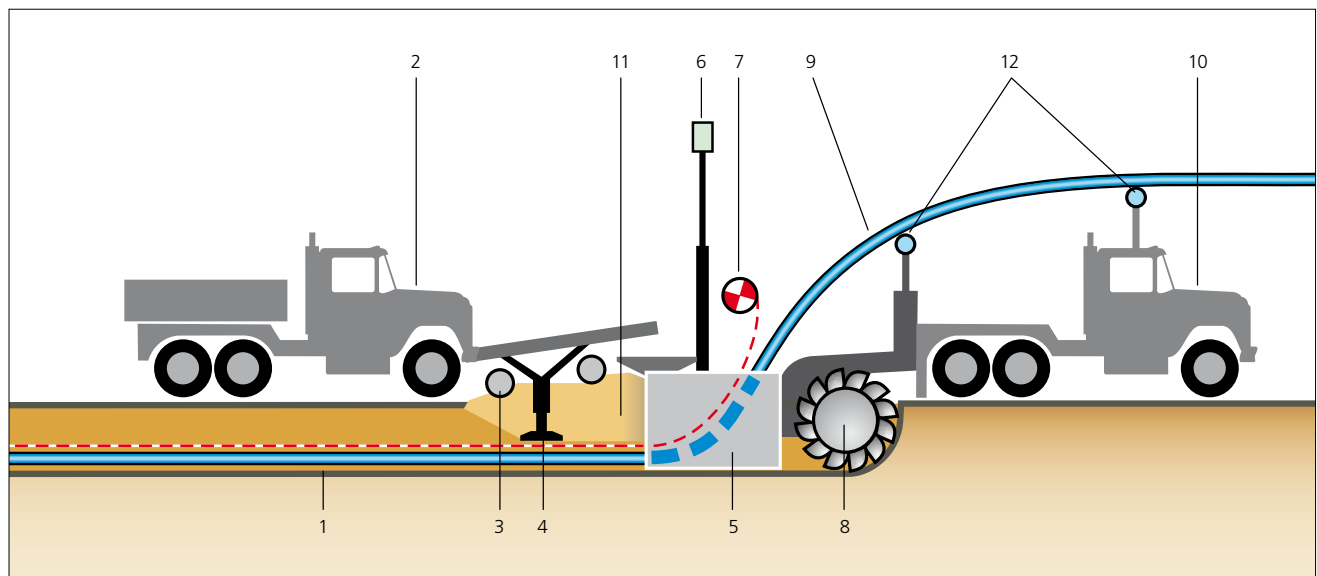

8.29 Narrow trenching | 1 trench bottom | 2 backfill and compaction unit | 3 axial screw conveyors | 4 compactor | 5 laying box | 6 laser receiver | 7 utility marking tape | 8 milling disc or cutter chain | 9 EMDS conduit | 10 trenching and laying unit | 11 extracted material (spoil) | 12 piping guides

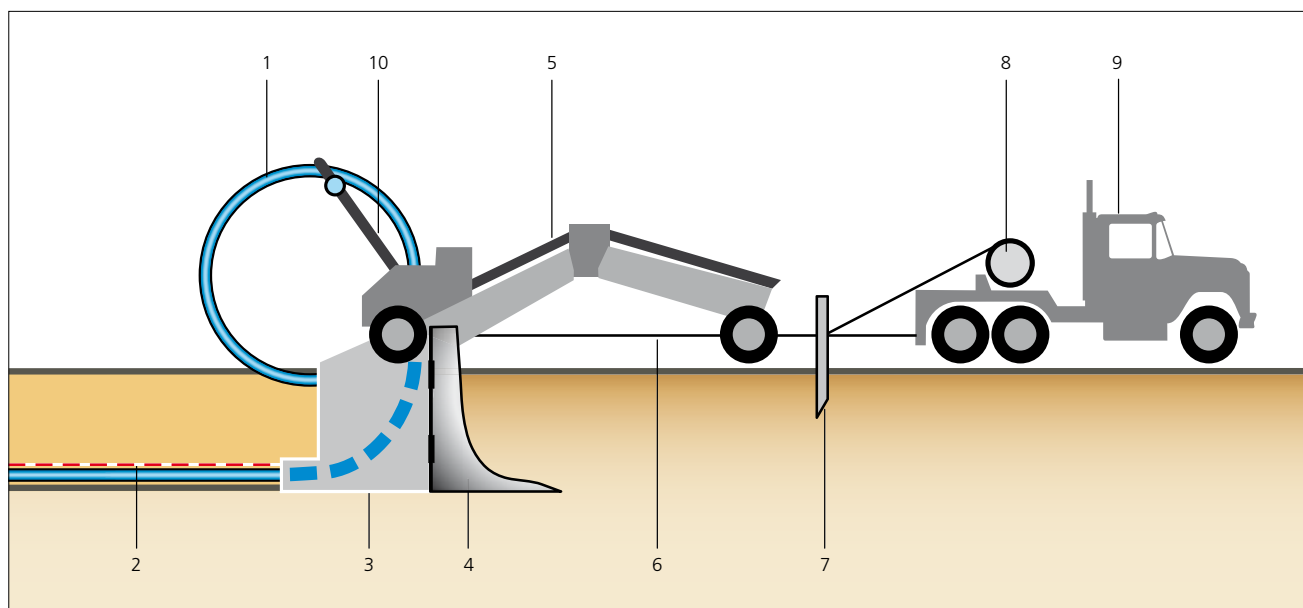

8.30 Ploughing | 1 EMDS conduit | 2 utility marking tape | 3 laying box | 4 plough blade | 5 plough | 6 pulling cable | 7 support | 8 cable winch | 9 winch truck | 10 piping guide

Soil displacement method

The soil displacement technique is an economical and proven procedure best suited for the construction of house laterals and used worldwide for three decades already. An air-operated displacement hammer, also known as "rocket", is driven through the ground to create an underground void into which the EMDS conduit pipes are introduced. There is no need to dig up or destroy existing surface structures or spaces like yards, gardens or traffic zones. Traffic will not be disrupted, and time and money can be saved for larger construction projects.

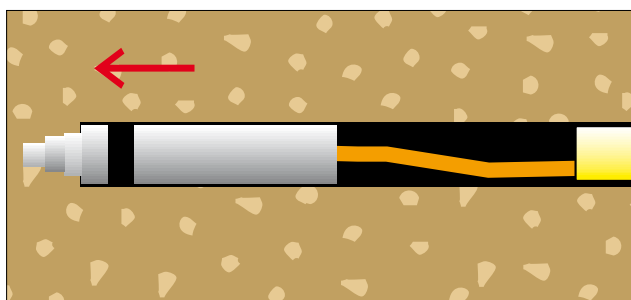

8.31 Soil displacement

Directional drilling method

The installation of a new pipeline according to the directional drilling method is performed in three consecutive steps. The first step is the localisation-controlled boring of a continuous pilot hole, which defines the pipe route. Then the pilot hole is enlarged to the diameter required for the introduction of the EMDS conduit pipe (reaming). In the third step, the butt fusion-jointed thrust-resistant piping is introduced into the enlarged hole. The inner weld beads should be removed to allow for easier introduction of the cables into the conduit. The buckling strength of the pipeline must be higher than the maximum pressure of the drilling fluid.

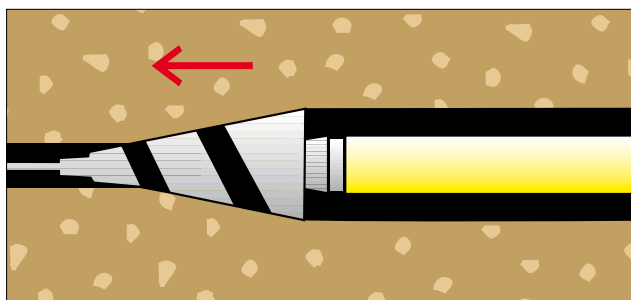

8.32 Directional drilling

The allowable bending radii and tensile forces must be adhered to in all methods. → Technical information, p. 58 et seq.

3.3 Jointing technologies

EMDS conduit pipes can be joined by means of appropriate jointing technologies according to the generally accepted engineering rules known for PE-HD pipes to form a pressure-sealed leak-free piping system.

The following table shows some of the common and recommended technologies for thrust-resistant pipe end-to-end and pipe-to-fitting joints according to current standards and guidelines.

Jointing method	Friction-locked/ detachable	Firmly bonded
Clamped, bolted or socket joints	✓	
Flange joints	✓	
Butt fusion*		✓
Electrofusion (fittings)		✓

8.33 Categories of jointing techniques | * not for PE-HD performance class

Welding shall meet the following requirements for PE-HD pipes:

- Qualification of welders according to DVGW GW 330 or DVS 2212-1
- Execution of works according to DVS 2207-1 and use of equipment according to DVS 2208-1
- Supervision of welding operations according to DVGW GW 331 or DVS 2212-1 (Supplement 1)

EMDS conduit pipes with protection jacket must be joined in compliance with the installation instructions of jacketed pipes (→ GEROfit®R, p. 140).

Butt fusion welding (HS)

The fusion ends of the pipes or pipe components to be joined are matched with a heater plate (initial bead-up phase), then heated to welding temperature at reduced pressure (heat-soak phase) and, after removal of the heater plate (changeover phase), joined under pressure (fusion jointing). The manufacturer’s information and instructions shall be observed.

Basic conditions

The welding area shall be shielded from unfavourable weather (e.g. humidity, wind, excessive sunlight, or temperatures below 0°C). If the pipe accumulates local heat from direct sunlight, the weld area should be covered early enough to bring the temperature down.

The mating fusion surfaces of the components to be welded must not be damaged and must be free of contamination (e.g. dirt, grease, chips). The fusion surfaces shall be cleaned directly before welding. As pipes may show ovalities after storage, it may be necessary to restore the shape of the pipe ends, e.g. by means of a re-rounding tool. End caps on the delivered pipes shall not be removed until immediately before the welding operation and then only at the ends to be welded.

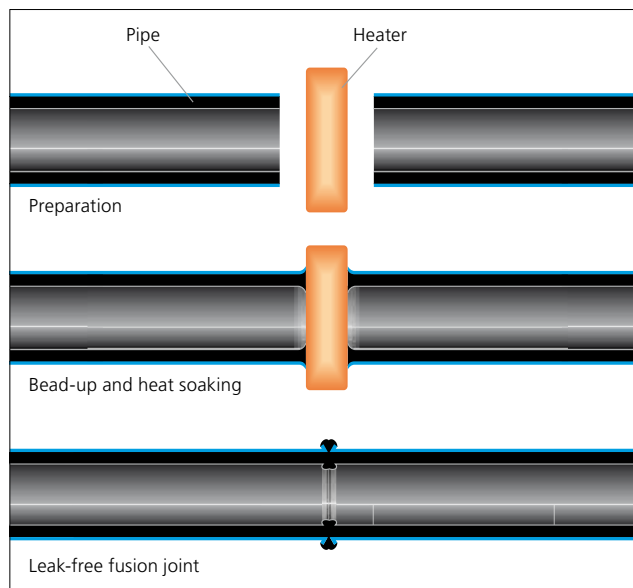

8.34 Principle of butt fusion welding

All tools and pieces of equipment mentioned in the following instructions are available as Gerodur accessories (→ Accessories, p. 309). The welding report (tem-

plate → p. 321) and the specified welding parameters (→ table 8.43, p. 268) shall be used to ensure proper performance of the procedure.

Work instructions according to DVS 2207-1 (HS)

1. Set up appropriate work conditions, e.g. a welding tent. → Fig. 8.36
2. Connect the welding device to the power mains or to a generating set and check its function.
3. Do not remove the end cap (delivered condition) from the pipe end opposite to the fusion end to avoid air draught.
4. Align and clamp the components to be welded. → Fig. 8.37
5. Smoothen the jointing surfaces of the pipes with a planing tool (blades must be sharp!). Then remove the tool and eliminate all shavings and chips from the welding zone. → Fig. 8.38
6. Check the planed jointing surfaces to make sure they are parallel. Check for offset (max. 0.1 x wall thickness). → Fig. 8.39
The allowable joint clearance is shown in the following table:

DN/OD	Allowable clearance
≤ 355mm	≤ 0.5mm
< 630mm	≤ 1.0mm

8.35 Allowable clearance (DVS 2207-1)

7. Check the temperature of the heater plate before starting to weld. To do so, use an instant-read instrument suitable for surface temperature measurements. Guide value for PE100: 220 °C.

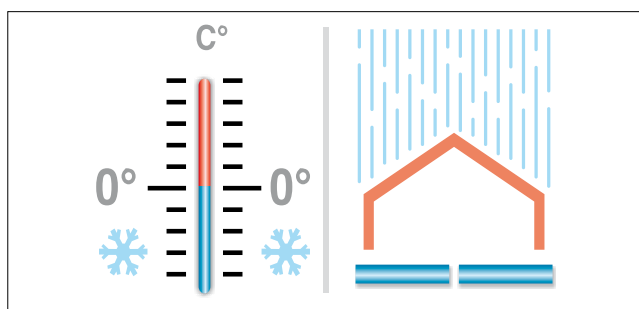

8.36 Set up and maintain appropriate work conditions

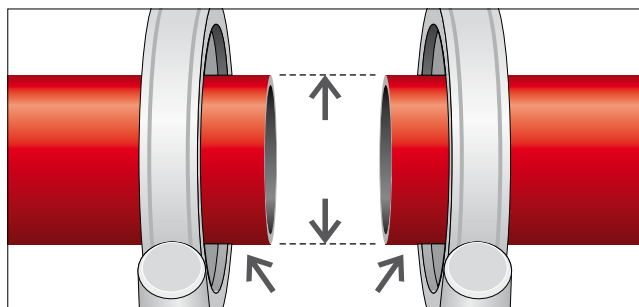

8.37 Clamp and adjust the pipe ends

8. Clean the heater plate with a non-linting paper.
9. Read the drag pressure or drag force on the welding machine and record the value in the welding report.
10. Determine the settings for the bead-up and jointing pressures, or the jointing force based on the guide value of 0.15 N/mm² for PE-HD pipe. The heat-soak pressure is 0.01 N/mm².

$$\begin{aligned} & \text{Jointing pressure (acc. to machine parameters)} \\ & + \text{ Drag pressure (setting)} \\ & \hline & = \text{ Bead-up or jointing pressure} \end{aligned}$$

11. All guide values (e.g. heat-soak time, jointing pressure or jointing force etc..) must be defined accordingly.

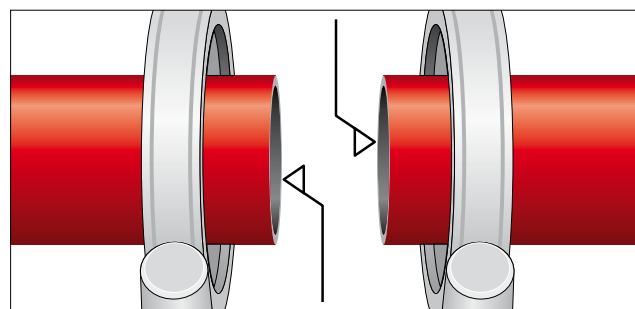

8.38 Planing

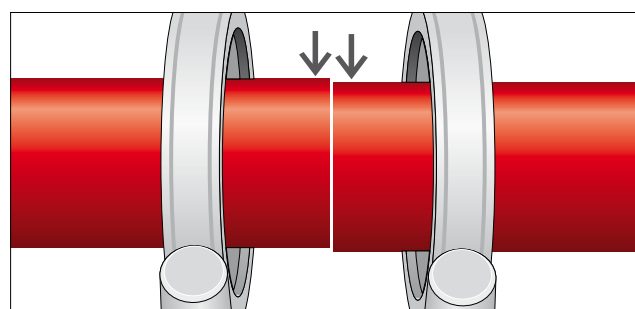

8.39 Check visually for offset and joint clearance

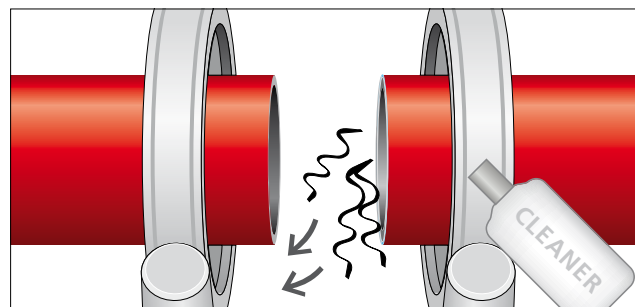

8.40 Remove chips and shavings in the jointing area and clean the fusion surfaces with PE cleaner

12. Where necessary, clean the fusion surfaces with an approved cleansing agent (e.g. PE cleaner) and paper in accordance with the following requirements. → Fig. 8.40

The cleansing agent, incl. the cleansing agent used for ready-made wetted cloths delivered by the manufacturer in a locking plastic box, must be composed of 100 % volatilising solvent, e.g. 99 parts of ethanol with 99.8 % purity and one part of MEK (methyl ethyl ketone, denaturing). Cleansing agents certified to DVGW V 603 fulfil these requirements. The safety data sheet (SDS) of the cleansing agent shall be observed. The wiping paper must be clean, first use, absorbent, unscented, non-linting and non-coloured.

13. Place the heater plate into welding position.
 14. Match the fusion ends with the heater plate until sufficient bead width. → Fig. 8.41

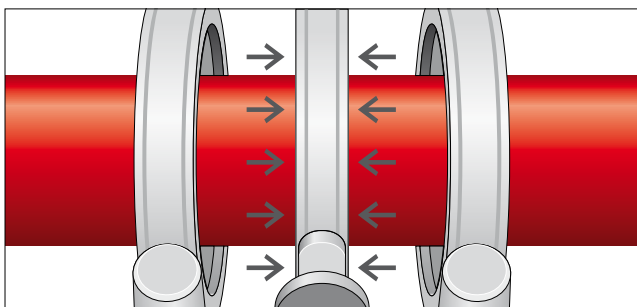

8.41 Initial bead-up and heat soak

15. Heat the fusion surfaces at reduced pressure (heat-soak time: 10 seconds per 1 mm wall thickness). Then remove the heater plate from between the jointing ends (change-over).

16. Bring together the molten ends within the changeover period (heater plate removal time). The velocity at contact must be near zero (as low as possible). Immediately join the molten ends continuously within the force build-up time until the required jointing force or required jointing pressure is reached. A proper weld will form a post-fusion bead ($K > 0$ according to DVS 2207-1). → Fig. 8.42

17. Maintain the jointing force until the weld has cooled down.
 18. After half the cooling time, it is recommendable to work off the inner weld bead. This will later facilitate the introduction of the cable.

19. After the cooling phase, unclamp the jointed components and complete the welding report.

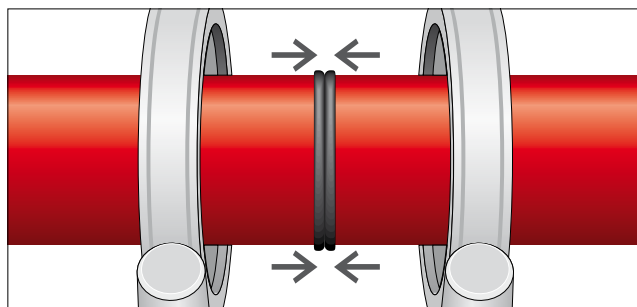

8.42 Changeover, jointing and final cooling under jointing pressure

Nominal wall thickness	Bead-up	Heat soak	Changeover	Jointing	
	Forming a specified bead size at end of initial bead-up time (minimum values) $p = 0.15 \text{ N/mm}^2$	Heat-soak time = 10 sec per 1 mm wall thickness $p \leq 0.01 \text{ N/mm}^2$	Heater plate removal time (maximum duration)	Jointing force build-up time	Cooling time under jointing pressure* (minimum values) $p = 0.15 \text{ N/mm}^2$
[mm]	[mm]	[s]	[s]	[s]	[min]
≤ 4.5	0.5	≤ 45	5	5	6.5
4.5–7	1.0	45–70	5–6	5–6	6.5–9.5
7–12	1.5	70–120	6–8	6–8	9.5–15.5
12–19	2.0	120–190	8–10	8–11	15.5–24
19–26	2.5	190–260	10–12	11–14	24–32
26–37	3.0	260–370	12–16	14–19	32–45
37–50	3.5	370–500	16–20	19–25	45–61
50–70	4.0	500–700	20–25	25–35	61–85

8.43 Benchmarks for butt fusion welding according to DVS 2207-1 | * Ambient temperature of 25–40°C | Guide values applicable to EMDS pipes between 25 and 40°C and at moderate movement of the air. At lower ambient temperatures, the cooling time acc. to DVS 2207-1 can be reduced. The heater plate temperature guide value is 220°C. Changeover time must be kept as short as possible to avoid impairment of weld quality.

Electrofusion (HM)

The fusion surfaces (external surfaces of the pipe, or core pipe, and internal surface of the electrofusion fitting) are electrically heated via heater coils integrated in the fitting and the fitting is welded to the pipe under fusion pressure. The automatic welding operation shall be carried out with appropriate equipment adapted to the fitting. Also, the manufacturer's information and instructions shall be observed.

Basic conditions

The welding area shall be shielded from unfavourable weather (e. g. humidity, wind, excessive sunlight, or temperatures below 0°C). If the pipe accumulates local heat from direct sunlight, the weld area should be covered early enough to bring the temperature down. Care shall be taken to maintain the pipe and the electrofusion fitting at almost identical temperature.

The mating fusion surfaces of the components to be jointed must not be damaged and must be free of contamination (e. g. dirt, grease, chips).

As pipes may show ovalities after storage, it may be necessary to restore the shape of the pipe ends, e. g. by means of a re-rounding tool. End caps on the delivered pipes shall not

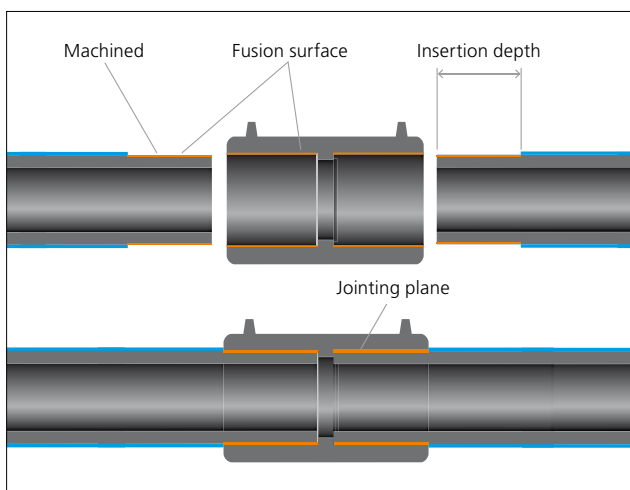

8.44 Principle of electrofusion welding

be removed until immediately before the welding operation and then only at the ends to be welded. The mating surfaces of the pipe and electrofusion fitting shall be cleaned directly before welding.

All tools and pieces of equipment mentioned in the following instructions are available as Gerodur accessories (→ Accessories, p. 309).

An appropriate welding report (template → p. 322) shall be used to ensure proper performance of the procedure.

Work instructions according to DVS 2207-1 (HM)

1. Set up appropriate work conditions, e. g. a welding tent. → Fig. 8.45
2. Connect the welding device to the power mains or to a generating set and check its function.
3. Remove the outside burr from the square-cut pipe ends.
4. Where necessary, use re-rounding clamps to restore the circularity of the pipe ends. Allowable ovality is 1.5 %, but no more than 3 mm.
5. Remove the oxidised layer on the pipe surface with a rotary peeling tool (hand scraper in exceptional cases only) at constant depth of about 0.2 mm. → Fig. 8.46
6. Remove the electrofusion fitting from the original package.

7. Clean the peeled pipe surface and internal fitting surface with an approved cleansing agent (e. g. PE cleaner) and a non-linting non-coloured paper. → Fig. 8.47

The cleansing agent, incl. the cleansing agent used for ready-made wetted cloths delivered by the manufacturer in a locking plastic box, must be composed of 100 % volatilising solvent, e. g. 99 parts of ethanol with 99.8 % purity and one part of MEK (methyl ethyl ketone, denaturing). Cleansing agents certified to DVGW V 603 fulfil these requirements. The safety data sheet (SDS) of the cleansing agent shall be observed. The wiping paper must be clean, first use, absorbent, unscented, non-linting and non-coloured.

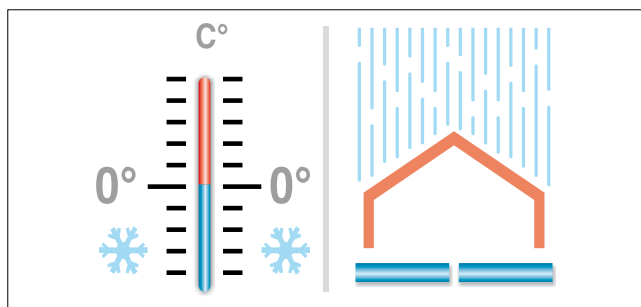

8.45 Set up and maintain appropriate work conditions

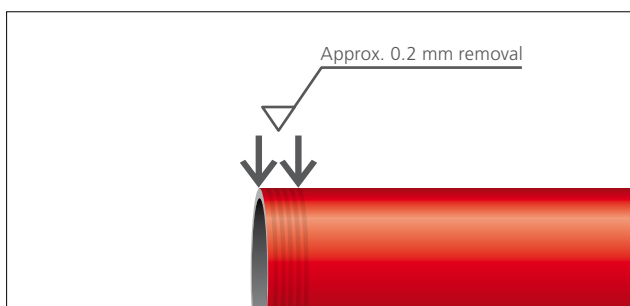

8.46 Machine the weld area, reliable with rotary peeler

8. Indicate the insertion depth with a visible mark on the pipe. We recommend a white marker pen without metal particles.
9. Insert the pipe end into the fitting without applying force. Make sure the ends are square and parallel, and secure the assembly.
- ! Make sure the insertion depth is correct and the assembly is stressfree; use a restraining device. (The tapping clamps or weld-on saddles shall be secured on the pipe surface with a restraining device!).**
10. Plug the cable of the welding machine into the fitting contacts by ensuring sufficient stress relief.
11. Check the settings or data indicated on the display as appropriate. Enter or scan the welding data into the machine. → Fig. 8.48
12. Perform or check the welding process according to the manufacturer's instructions.
13. Unplug the cable from the fitting.
14. Observe the cooling time specified by the manufacturer, then unclamp the retaining device (not required for certain tapping clamps with integrated holder – refer to the manufacturer's instructions).
15. If no automatic report is issued, draft a manual welding report.

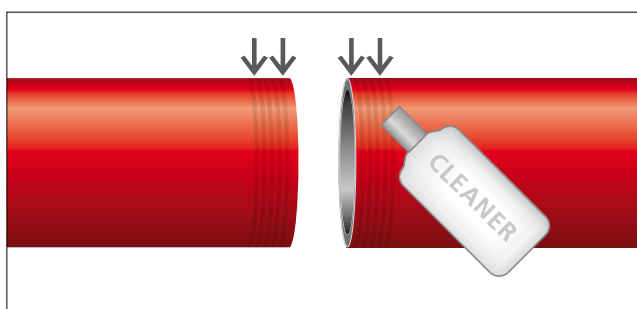

8.47 Clean the fusion surfaces with PE cleaner

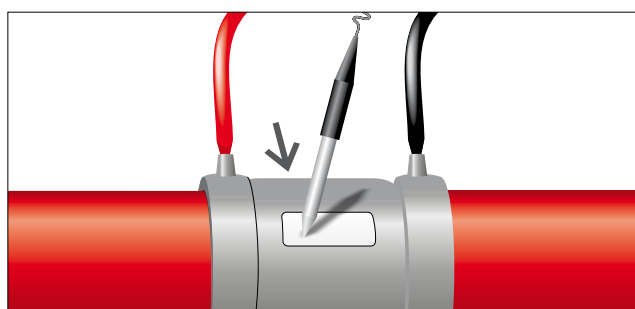

8.48 Scan the parameters (bar code), then weld and observe the cooling time

Special requirements

The following is a brief summary of special requirements applicable to butt fusion welds according to DVS 2207-1:

- The weld area must be protected from unfavourable weather impacts, such as:
 - Moisture, snow, hoarfrost, etc.
 - Ambient temperature below 0°C
 - Wind
 - Extended exposure to sunlight
- Welding at temperatures below 0°C is possible under the mentioned conditions when a sufficient pipe wall temperature is guaranteed by tenting, warming-up, heating, without impairing the manual skills of the welder.
- Under the mentioned conditions, it may be necessary to perform test welds to provide additional proof of suitability.
- A uniform temperature level shall be maintained for the pipes and fittings to be welded.
- Pipes, fittings and pipe components must have the same SDR for welding (exception: SDR 17.6 with SDR 17).

Further information

Welding operations need to be supervised according to GW 331 or DVS 2212-1 (Supplement 1). It is strongly advised to perform the welds in compliance with DVS 2207-1 and to use welding equipment meeting the requirements laid down in guideline DVS 2208-1, or to work in accordance with national guidelines conforming thereto.

It is recommended to record the welding data of the different job sections separately by nominal diameters. For welding report templates according to DVS 2207-1, → Appendix, p. 321 et seq.

Use of tapping fittings

The mounting requirements for tapping fittings on EMDS conduit pipes are not different from general technical rules.

EMDS conduit pipes with additional protective jacket are governed by specific instructions (→ GEROfit®R, p. 146).

Other jointing technologies

Clamped, bolted and socket joints

We recommend exclusive use of products approved by DVGW for PE-HD pipes. The manufacturer's instructions shall be complied with.

Flanged joints

Flanged connections shall be performed with corresponding stub ends (long – electrofusion, short – butt fusion). Stub ends shall have the same SDR class as the pipes. The backing rings must match the given pressure rating. The flange manufacturer's instructions shall be complied with. The axes of the pipe components to be joined must be properly aligned. Bolts must be tightened in a crosswise pattern (observe torque specifications if any).



8.49 Re-rounding clamps for EF joints (source: +GF+)

PE pipes tend to flatten during storage. If ovality in the weld area is $> 1.5\%$ of the DN/OD or ≥ 3.0 mm, the pipes must be re-rounded with an appropriate tool (re-rounding clamps). The mounting instructions of the joint manufacturers must be complied with.